

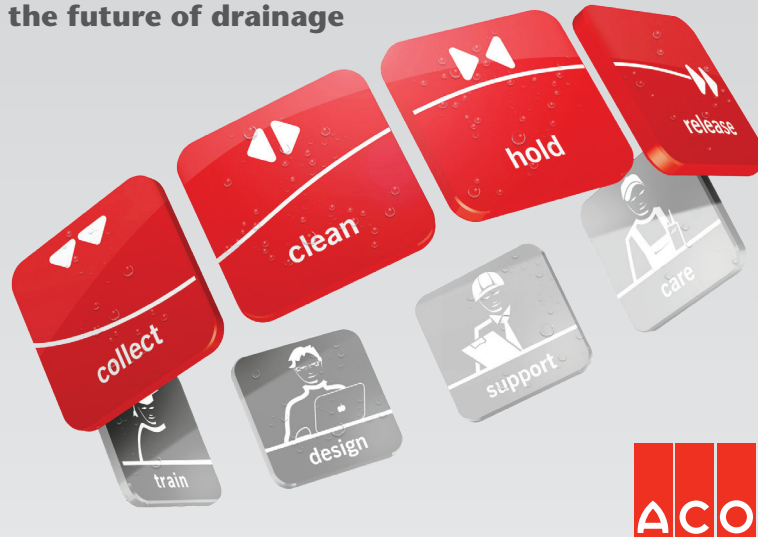

**Drainage and Grease Management
for the Commercial Kitchen**



ACO. creating the future of drainage



Hostile environments, hot water and grease must be counteracted by more complex and sophisticated drainage concepts. ACO achieves this with intelligent system solutions which address food safety, water protection and people safety. Every product within the ACO system safely controls the water as it passes along the chain to ensure that it can be hygienically, economically and ecologically handled in a viable way.

As the leading manufacturer of drainage solutions, we pride ourselves on being experts in all aspects concerning drainage. ACO's comprehensive expertise is available for our sales partners, as well as architects, planners and the trades. This not only helps us simplify your working day, but also enables us to safeguard the quality and market leadership of ACO solutions.



Collect

The surface water or the liquids being treated are collected from the surface as quickly and completely as possible by the drainage system. This part of the ACO system chain guarantees protection, safety and comfort for the people, buildings and traffic routes in the immediate vicinity.



Clean

The collected liquids are treated using integrated physical, chemical or biological processes that ensure they can be discharged into the public sewers. This part of the ACO system chain creates the conditions for recycling and sustainable use.



Hold

Containers, barriers and valves ensure that liquids stay within the drainage system where they can be properly controlled. This part of the ACO system chain enhances the protection and safety of food, building and environment.



Release

Pumps, lifting plant and pipe systems transfer the collected, treated and controlled water into the downstream systems and processes. This part of the ACO system chain brings the collected, treated and controlled water to the interfaces for further treatment, re-use or release.



Train

We share the expertise of the global ACO Group with dealers, planners, architects and installers, who place a big priority on quality. We invite you to take advantage of our expertise and attend ACO educational trainings.



Design

The design and planning of drainage solutions is associated with many alternatives. We will help you find which concept produces the most economical, hygienic and safest technical solution.



Support

We provide you with project-related advice and support to ensure that no surprises occur between the planning and implementation of a drainage solution.



Care

ACO products are designed and built for long service lives. Our customer care services ensure that ACO continues to satisfy your high quality requirements year after year.

CONTENT

ACO system & service chain	02
<hr/>	
About ACO	04
<hr/>	
HygieneFirst	06
<hr/>	
Drainage Management	08
<hr/>	
Drainage & Grease Management for the Commercial Kitchen	09
<hr/>	
Features of ACO drainage	10
<hr/>	
Grease Management	13
<hr/>	
Commercial kitchen processes	16
<hr/>	
Product overview	18
<hr/>	



About ACO

About ACO USA

ACO in the USA is a sales and marketing company with strong manufacturing bases and introduced the concept of modular trench drains to North America over 30 years ago. ACO offers field support for all aspects of the business - from specification advice to installation expertise. As the market leader, ACO USA is constantly innovating to bring new products to the market. ACO has a fully established R&D department responsible for continuous development, quality and testing to ensure ACO products continue to lead the market.

Who we are

ACO is the established leader in providing drainage systems for the food service industry. Each drainage system is designed to provide maximum reliability, longevity and durability while preventing hygienic issues that can put your facility at risk. More than 60 years of drainage experience make ACO the world-class supplier of drainage systems.

What we do

ACO drainage and grease separation systems are designed around the three most important topics for the food service industry: food safety, cost management and health & safety. We design our products to drain processed wastewater hygienically and economically, exceeding the highest worldwide standards such as those laid out in the European Hygienic Engineering and Design Group (EHEDG).

Where we are



With sales offices throughout the world and 29 modern production sites situated throughout all continents, we are fully conversant with international standards and also work extensively with key industry entities to stay ahead when it comes to creating the most modern systems available.

Why choose us

We work hand-in-hand with commercial kitchen specialists and designers to create systems suited specifically to their needs. When using ACO drainage systems you can expect design with emphasis on hygienic performance and the highest level of confidence that you are using the best drainage system on the market.





 Stainless Steel production
 ACO organization

ACO at a glance

- ACO - The Ahlmann Company
- Founded in 1946
- A family owned business
- Manufactures products for the building and construction industries
- Employs over 4,000 people world-wide
- Sales and manufacturing operations in more than 45 countries
- The world leader and pioneer of modular trench drain systems
- ACO products have been used at many prestigious locations, including nearly every Olympic venue since 1972
- The ACO Group is split into regional sub-groups; the USA is head of, and part of the Pan Pacific Group - along with Canada, Mexico, Central America, Australia, New Zealand, Pacific Islands, and Southeast Asia

Global development in sales in million US \$

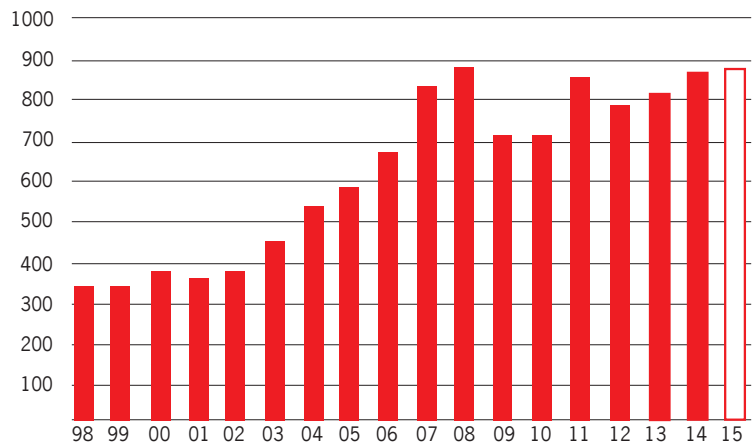

5



The ACO Group

"A strong family you can build on"



Hygiene**First**

As one of the world's leading commercial drainage specialists, the ACO Group understands the critical role that drainage plays in a successful commercial food preparation business. We appreciate that food safety, hygiene and cost control are all vital factors, yet we also understand that for many, drainage is out of sight and out of mind.

As a result, many drainage systems are not designed well, which leads to inefficiencies and a higher lifetime cost. In a worst case scenario, this can also result in food contamination, closure of a facility and the loss – or even closure – of a business. As the company that is driving the future of drainage, we are determined to change this by raising the profile of hygienic drainage and improving standards across every part of the process.

Our HygieneFirst philosophy represents our commitment to delivering products that provide ultimate hygienic performance. We design intelligent drainage solutions that minimize operational costs without compromising food safety.





Drainage Management

Hygienic standards in the commercial kitchen industry are rising. ACO is meeting these changing demands by incorporating hygienic design principles, industry best practices and guidelines including the European Hygienic Engineering and Design Group (EHEDG) into the design of its drainage solutions.

Operational costs are a major factor in business today. Every product and system needs to fulfill its function efficiently throughout its entire lifespan. ACO provides the expertise and quality necessary to give the perfect balance between high levels of food safety and operational cost.

The kitchen is a potentially hazardous environment because of the ever-present element of heat, liquids and grease. ACO drainage systems are specifically designed to reduce the build-up of liquids by disposing of water and grease effectively and immediately.



Drainage & Grease Management for the Commercial Kitchen

Commercial kitchens are extremely busy environments with potentially wet and greasy floors due to the abundance of liquids used in both the cooking and cleaning processes, and of course, liquids are often very hot. Waste water can also contain fat, which is a major cause of pipe blockages and cannot be released to the waste water system. In combination, these factors may affect food safety, operational cost and health & safety.

Food safety

Food safety can be severely affected due to poor drainage and grease separation systems. ACO solutions are designed to effectively and safely drain away and handle process water. We design our products specifically to reduce the risk of food contamination.

Cost control

Management of costs is a major factor in business today. Commercial kitchen equipment, including drainage and grease separation systems, should fulfill their function with low operational costs in mind throughout its entire lifespan. ACO drainage and grease separation systems are designed so they can be easily maintained, reducing associated cleaning costs and maximizing hygienic performance.

Health & safety

Minimizing the risk of injury in the workplace is of major importance to any commercial kitchen facility. It is essential that your facility has a drainage system which improves health and safety conditions during cleaning, emptying and operation, while ensuring hygiene is always front of mind.



Food safety features of ACO drainage

ACO hygienic drainage fulfills hygienic requirements to prevent harmful bacteria contamination. We apply relevant hygienic design principles reserved for food contact surfaces recommended by European standards.

Our product design ensures minimal buildup of food particles and debris as well as a safe connection with the surrounding floor to minimize any opportunity for bacteria to grow throughout the drainage system.

A sleek slope and hygienically designed products ensure our systems are fully drainable, eliminating the stagnant odor of waste water.

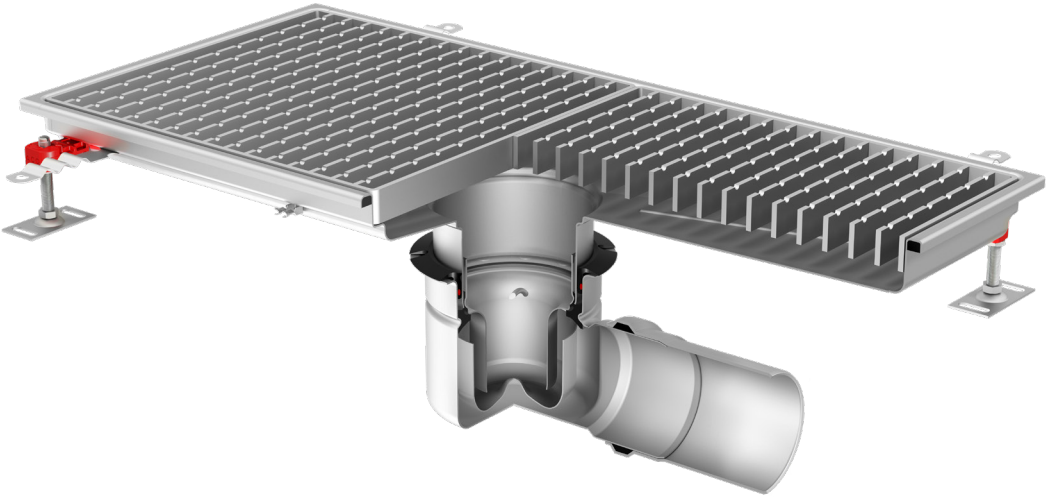
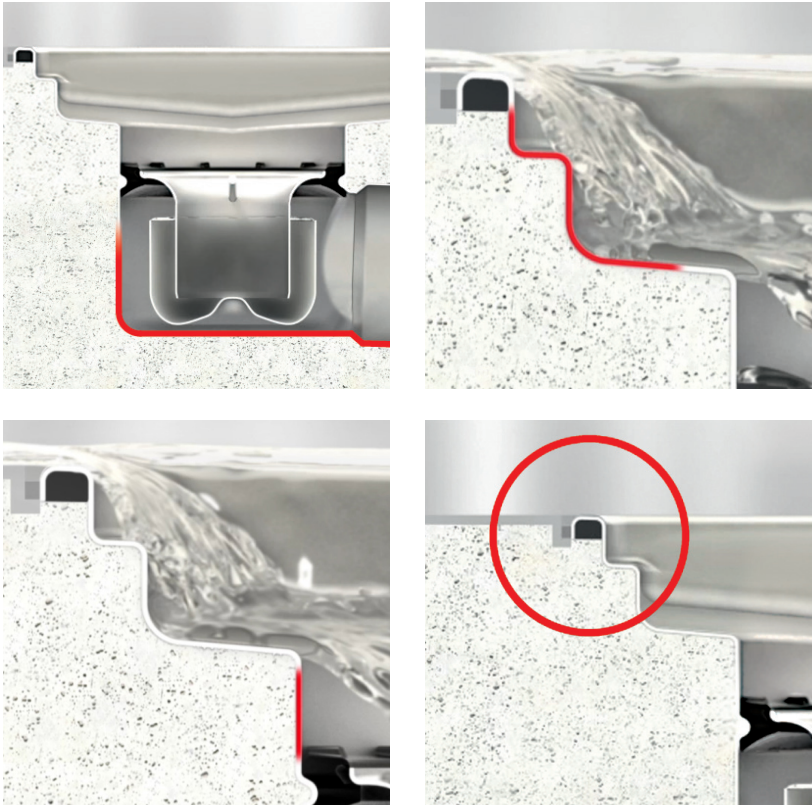

Cost control features of ACO drainage

ACO drainage systems can be easily maintained, reducing associated cleaning costs, thanks to their functional design and cleaning recommendations which have been developed in partnership with premium cleaning agent suppliers.

ACO's advanced manufacturing technologies ensure durability and our special surface treatment guarantees corrosion resistance. Our systems perform effectively at all times and keep disruption to a minimum.

We provide expertise in drainage system planning, correct installation and creating a safe connection with the surrounding floor to avoid unnecessary costs.

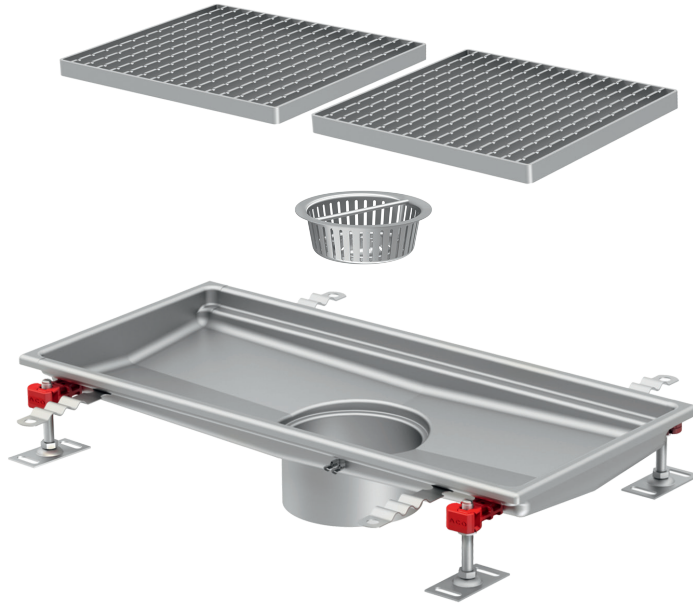

Health & safety features of ACO drainage

For additional safety in high risk areas that require heavy water usage, a slip resistant ladder and cast grating is available.

Each component of the drainage system is easy to remove and clean, and there are no sharp edges to ensure employee safety.

ACO drainage products also have a fire resistant solution.

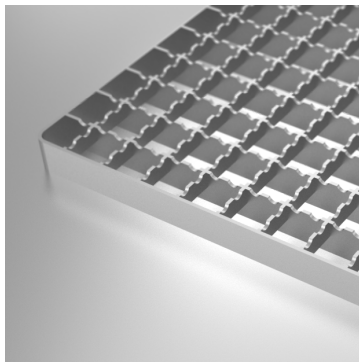
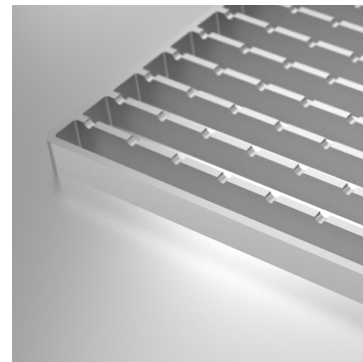
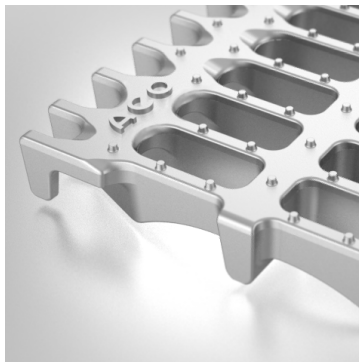

ACO



Grease Management

Commercial kitchens generating waste water must have pre-treatment plants to ensure that solids and liquids that release harmful or unpleasant vapors or interfere with operations are not discharged into the public sewer network.

In addition to odor reduction, ACO systems also reduce the amount of work required to handle grease disposal and cleaning. For example, if a grease separator features automated cleaning, it is no longer necessary to use external cleaning equipment. The use of the filling device also allows refilling to take place directly at the separator.

Health & safety is of prime importance in a commercial kitchen operation with particular attention being paid to process reliability and fire prevention.

Food safety features of ACO grease separators

ACO grease separators eliminate unpleasant smells during cleaning and disposal.

Effective hydro mechanical high pressure 360° internal cleaning (175 bar) removes all residue in the separator.

Grease separators are available in stainless steel for optimal hygiene.

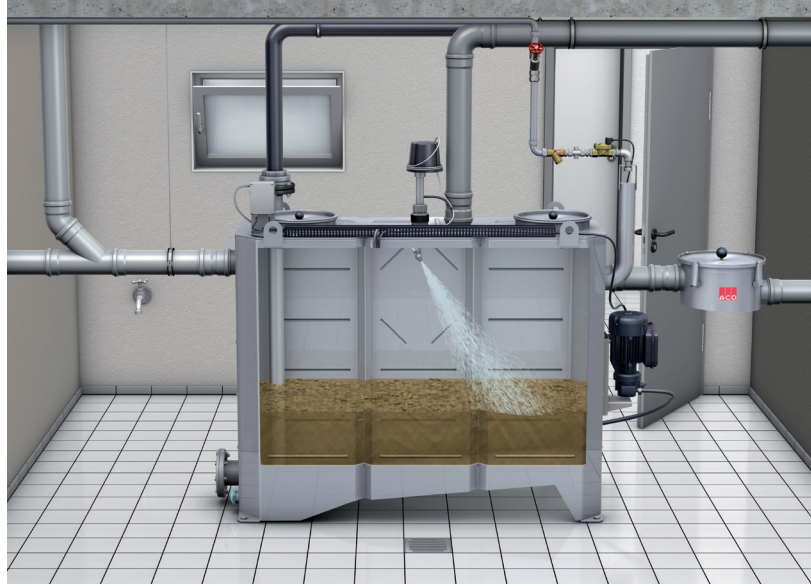

Cost control features of ACO grease separators

ACO grease separators automatically measure the grease layer, so the operator knows when they need emptying.

Operational flexibility is ensured by our GSM Mobile module. Information about inspections and maintenance needs are sent to mobile phones.

Operational costs are optimized due to automatic cleaning and grease disposal.

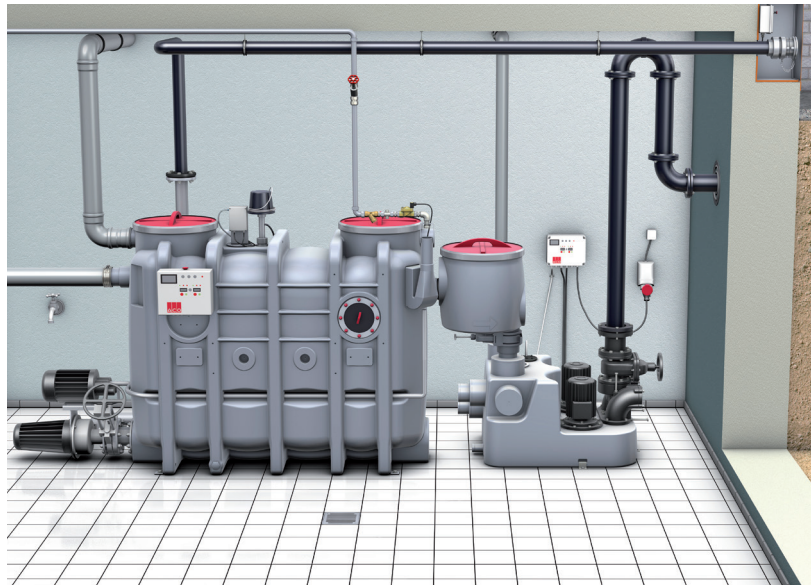

Health & safety features of ACO grease separators

Benefiting from automatic cleaning, ACO's grease separators eliminate any health and safety risk during disposal and cleaning.

Sizing, layout and the right solution specification support help ensure safe installation and maintenance.

ACO grease separators offer a stainless steel incombustible solution.

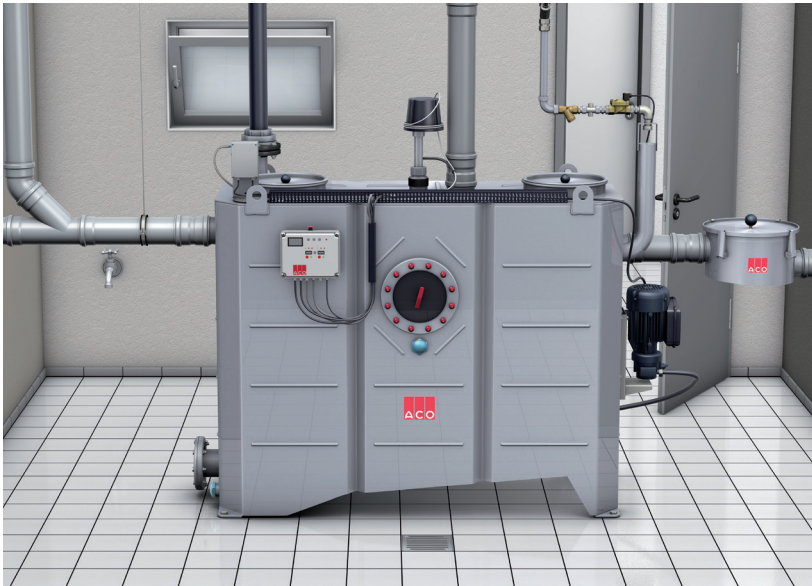

Commercial Kitchen

There are three principal areas in every commercial kitchen: the storage and preparation area, the production area, and the washing and disposal area. Each area handles different processes in the commercial kitchen environment and has different demands for waste water management. Nevertheless, there are some aspects which are common for all three.

A well-designed drainage system should have:

- A debris filter at outlet
- Easily removable non-slip gratings
- Easily removable foul air trap
- Hygienic design to avoid bacteria traps
- Proper volume capacity size
- A grease separator for removal of fats and grease

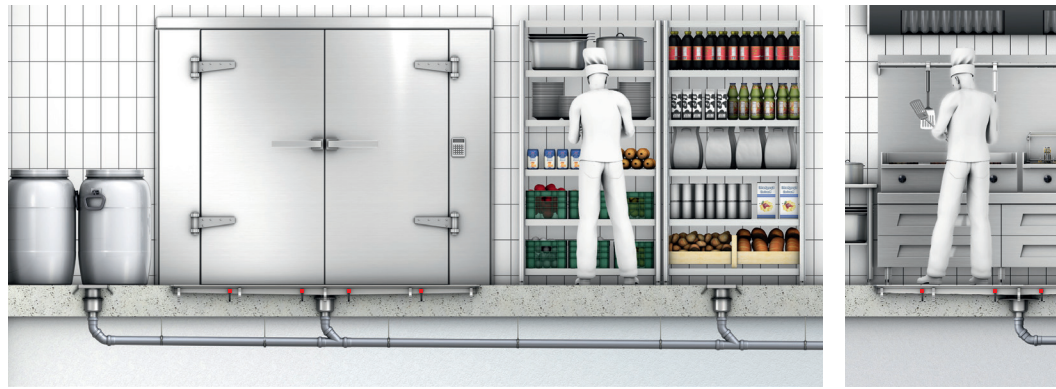

Storage area

Preparation area

▶ **Drainage Management**



ACO hygienic floor drain



ACO modular box trench drain

▶ **Grease Management**

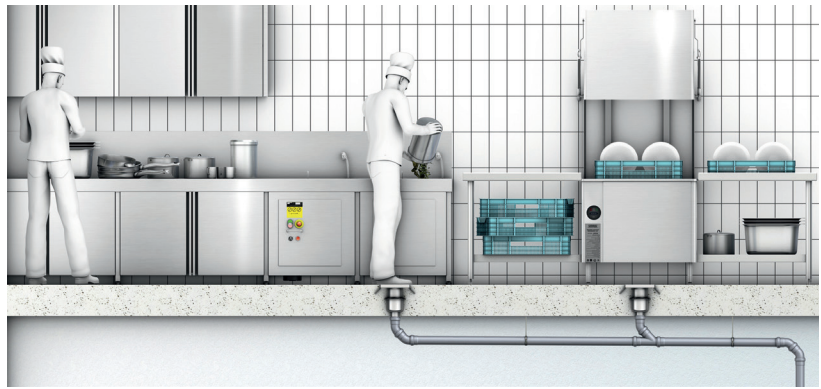
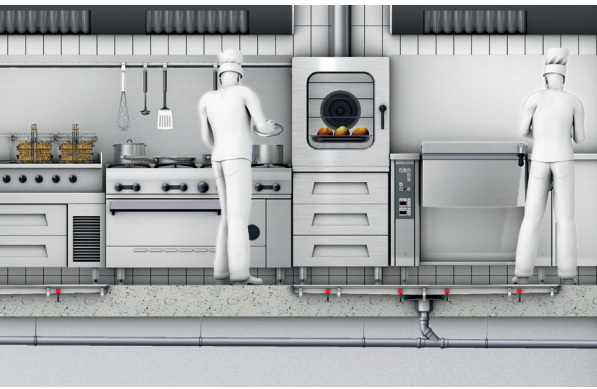

Production area

Washing area

Disposal area

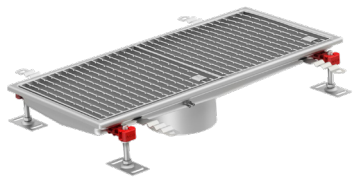

ACO hygienic trough

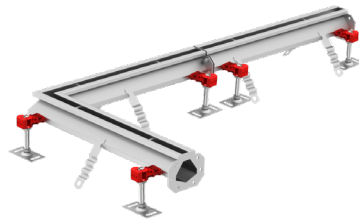

ACO modular slot trench drain



ACO pipe



ACO Lipumax P-DA



ACO Lipurat-RAE

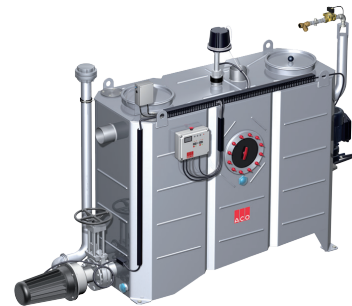

ACO Lipurat-OAE

Product overview

ACO hygienic floor drain

The ACO hygienic floor drain range incorporates hygienic design principles to ensure optimum hygienic performance. ACO hygienic floor drains are available in three body sizes to cater for different flow rates and construction requirements, including shallow construction depths and applications where preventative fire measures are required.

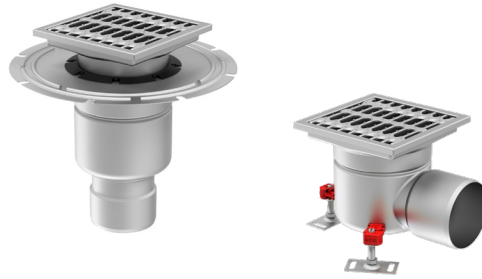

ACO hygienic trough

The ACO hygienic trough range incorporates hygienic principles to ensure optimum hygienic performance. The hygienic trough range is ideal for applications where high standards of hygiene are required as they are capable of handling large volumes of fluid.

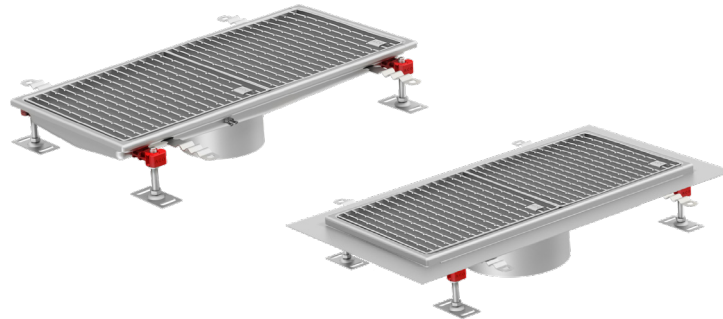

ACO modular box and slot trench drain

Our modular range with standardized 20, 125 and 200 mm widths provides a most versatile system with off-the-shelf availability. Accessories, such as corner units and a choice of grating, make this system perfect for a wide range of applications.



ACO pipe

A stainless steel push-fit pipe system designed for grey or black water. ACO pipe offers a product life in excess of 40 years, thanks to the use of stainless steel. Easy installation and on-site handling is ensured by push-fit assembly. ACO pipe is more hygienic, robust and durable than plastic pipe systems for gravity and vacuum drainage.



ACO grease separators

A comprehensive range that addresses all size requirements specified by European standards, with performance at or beyond the standard's requirement. Our separators can be specified with varying degrees of sophistication: grease removal and cleaning maintenance can be automated, minimizing disruption in busy catering environments. Separators are tested and certified according to European standards.



ACO, Inc.

West Sales Office

825 W. Beechcraft St.
Casa Grande, AZ 85122
Tel: (520) 421-9988
Toll Free: (888) 490-9552
Fax: (520) 421-9899

Northeast Sales Office

9470 Pinecone Drive
Mentor, OH 44060
Tel: (440) 639-7230
Toll Free: (800) 543-4764
Fax: (440) 639-7235

Southeast Sales Office

4211 Pleasant Road
Fort Mill, SC 29708
Toll Free: (800) 543-4764
Fax: (803) 802-1063

Electronic Contact:

info@acousa.com
www.acobuildingdrainage.com

© May 2018 ACO, Inc.

All reasonable care has been taken in compiling the information in this document. All recommendations and suggestions on the use of ACO products are made without guarantee since the conditions of use are beyond the control of the company. It is the customer's responsibility to ensure that each product is fit for its intended purpose and that the actual conditions of use are suitable. ACO, Inc. reserves the right to change products and specifications without notice.

Re-order Part # BD002 v1.0

